

# METAL EARTH™

## 3D LASER CUT MODELS

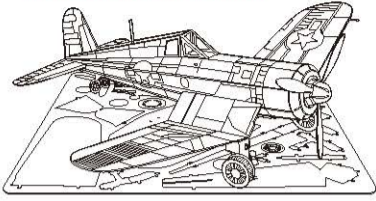

It is highly recommended that you visit [www.fascinations.com/meteearth360/mms035](http://www.fascinations.com/meteearth360/mms035) to see the completed model before assembling your own  
Vor dem Zusammenbau Ihres Modells besuchen sie bitte <http://www.fascinations.com/meteearth/gallery360> für die Ansicht des aufgebauten Modells.



mms035

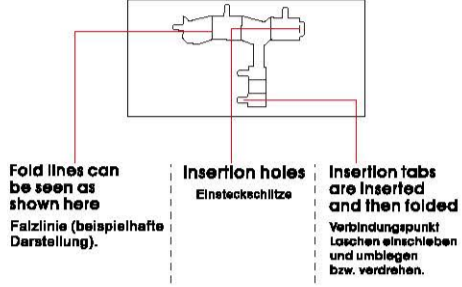

### To create the best connections Beste Verbindungen

**Insert tab and bend 90 degrees for most visible areas**  
Laschen einfügen und 90° umbiegen (bei den meisten sichtbaren Flächen).

**Insert tab and twist 90 degrees is best in some areas to ensure a tight connection**  
Laschen einfügen und um 90° verdrehen (in einigen Bereichen für eine straffe Verbindung sinnvoll).

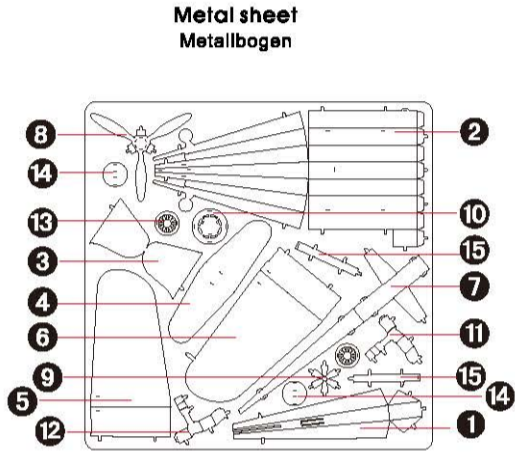
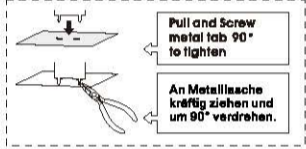

**Warning:** In order to avoid possible injury from sharp edges, please carefully discard the metal sheet after parts have been removed  
Nach dem Herauslösen aller Bauteile den Rest des Metallbogens sicher entsorgen, um Verletzungen an scharfen Kanten zu vermeiden.

This product is not a toy. Keep out of reach of children.  
Sammelmodell - kein Kinderspielzeug. Von Kindern unter 14 Jahren fernhalten. Alter: 14+

### Assembly Flow Chart Ablaufschema für den Aufbau des Modells

